

# GURU

*photon*

Guru Cycles Inc.  
2460 rue Michelin  
Laval (Quebec) Canada  
H7L 5C3

Customer Service  
t. 1877 755 GURU  
email. [customerservice@gurucycles.com](mailto:customerservice@gurucycles.com)

# Photon Instruction Manual

Congratulations on the purchase of your custom-made Guru Photon, the lightest frame in the world!

The Photon is at the pinnacle of what can be achieved with composite materials. Because of this, it requires particular care in handling during assembly, storage and riding. This short manual contains instructions that must be followed diligently to ensure years of trouble-free riding.

If you have any doubt regarding your mechanical ability and/or the instructions below, please visit your local authorized Guru dealer. Guru recommends that components be installed and maintained by a qualified Guru mechanic.

**NOTE: Failure to follow the torque specifications detailed in this guide will void the warranty, but most importantly may result in damage to the frame which may not be visible. A damaged frame can result in a loss of structural integrity, which may result in serious injury or death.**

Before assembling components onto your Photon, make sure that all parts are fully compatible. Ex. Handlebars should be compatible with the handlebar stem, the stem should be compatible with the fork steerer, etc. Any doubts regarding compatibility should be discussed with your local authorized Guru retailer.

**NOTE: Have a torque wrench handy as you will need it to tighten bolts according to the following specifications:**

- a. Saddle clamp: 5 Nm
- b. Front/ rear brake: 5 Nm
- c. Front der. hanger : 6.5 Nm
- d. Rear der. hanger : 8 - 10 Nm
- e. Water bottle cages : 3 Nm

If working on a stand with a clamp please ensure to:

- i. Place the clamp on the seat tube directly underneath the top tube.
- ii. Take care not to apply excessive force when squeezing the tube into the clamp and closing the jaw.

The integrated seat post of the Guru Photon is fully customizable and needs to be cut and adjusted to the personal saddle height of the cyclist.

To do so please follow these Steps:

- 1) Prepare your tools in advance.
- 2) Place the frame in the bike stand & install components prior to cutting the seat mast
- 3) Cut the seat tube mast to length.

## 1) Tools:

- a- Bicycle stand
- b- Torque wrench
- c- Allen keys
- d- Tape measure
- e- Saw with Carbon cutting blade
- f- Park cutting tool- ITEM # SG-6 (usually used to cut fork steers)
- g- Marker
- h- 400 grit sandpaper

2) Place the frame in the bicycle stand and install all the components (except the saddle/saddle clamp) prior to cutting the seat mast.

**NOTE: Please make sure to place the clamp below the top tube to avoid damaging the frame. Refer to Fig.1**

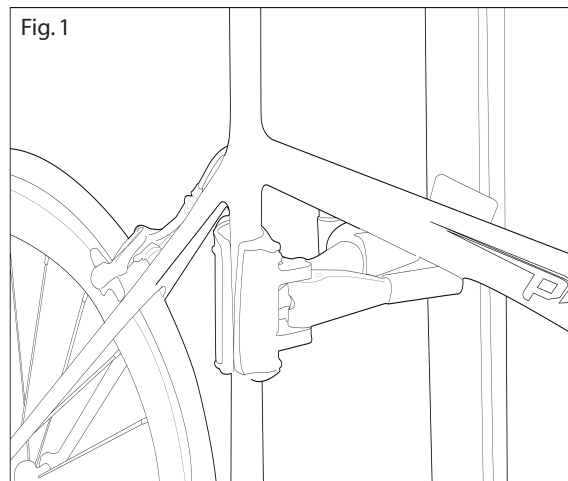

## 3) Cutting the seat mast to length:

a- Determine saddle height from the center of BB with the help of an expert fitter. (SH)

b- Install saddle on the saddle clamp.

c- Install plastic seat topper inside the uncut seat mast (the bolt on top should be fully screwed in)

d- Install the saddle clamp and saddle onto the seat mast. Make sure that the saddle clamp is fully inserted onto the seat mast.

e- Measure the top of the saddle to the center BB. (DI)

**f- Subtract: DI – SH = Cut length (CL)  
Refer to Fig.2 & Fig.3**

g- Please make sure that the mast height at the cut line is 190 mm or less (from the top of the top tube to the top of the seat mast). **If there is a complication please contact your local Guru dealer.** Refer to Fig.4

h- Remove saddle/saddle clamp and plastic seat topper from seat mast.

i- Cut at distance CL from the top of the seat mast using a blade specifically made for cutting carbon. Refer to Fig.3

In order to create a proper cut, use a Park cutting tool and apply minimal pressure when fastening to the seat post (do not over torque, simply ensure that the tool stays in place)

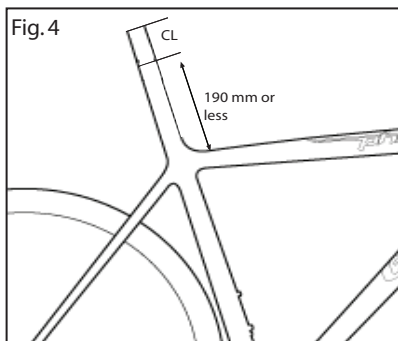
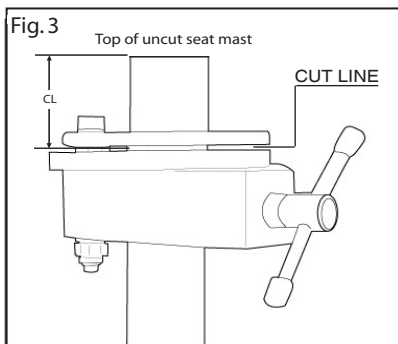
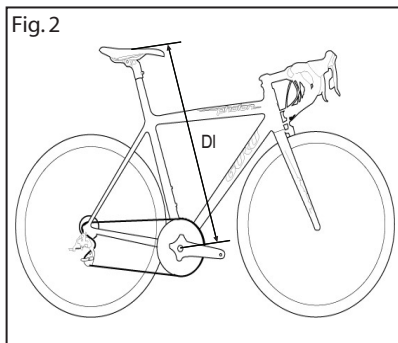

a. Make your cut using a blade specifically made for cutting carbon. Standard blades may damage the seat tube mast and will void the warranty.

b. Sand the top portion of the seat mast with 400 grit sandpaper to remove any burrs.

c. Using the same 400 grit sandpaper, lightly sand the top 2.5 cm of the seat mast. This will prevent slippage between the saddle clamp and seat mast.

d. Install the plastic seat topper with bolt fully screwed in. (Mandatory)

**NOTE: Tightening the seat clamp on the seat tube without the use of the plastic seat topper can damage the frame and will void the warranty.**

e. Install saddle and saddle clamp onto the seat mast ensuring that the saddle clamp sits firmly on the screw head of the plastic seat topper.

f. Measure distance between center of BB and top of the saddle to ensure that the distance is in fact equal to SH.

g. If it's too long, go back to step 3 and restart.

h. If you cut too much material, **don't worry**, the seat topper has been designed to provide you with an additional 15mm of height. Do not unscrew the seat topper screw beyond its minimal insertion line.

**NOTE: Use of a 3rd eye chain catcher is mandatory. Damage caused by chainsuck is not covered by the warranty.**

**NOTE: Great care should be taken not to damage composite materials, including the frame and any composite components. Any damage may result in a loss of structural integrity, which may result in a catastrophic failure. This damage may not be visible in inspection. Before each ride, and after any crash, carefully inspect the bicycle for any dents, fraying, gouging, chipping, bending, scratches or any other signs of damage. Do not ride if the bicycle shows any sign of these signs. After any crash, and before riding any further, take the bicycle to an authorized Guru retailer for a proper and complete inspection.**